

PROGRESSIVE METHODS IN THE AREA OF TURBOJET ENGINES' CONTROL SYSTEMS

Rudolf ANDOGA^{****}, Ladislav FÓZŐ^{***}, Ladislav MADARÁSZ^{*}, Tomáš KAROL^{*}

^{*}Department of Cybernetics and Artificial Intelligence, Faculty of Electrical Engineering and Informatics,
Technical University of Košice, Letná 9, 042 00 Košice, Slovak Republic

^{**}Department of Environmental Studies and Information Engineering, Košice, Faculty of Mechanical Engineering,
Technical University of Košice, Letná 9, 042 00 Košice, Slovak Republic

^{***}Department of Avionics, Faculty of Aeronautics, Technical University of Košice, Rampová 7, 042 00 Košice, Slovak Republic
e-mails: {rudolf.andoga}, {ladislav.fozo}, {ladislav.madarasz}, {tomas.karol} @tuke.sk

ABSTRACT

The article deals with modern concepts of control systems used in turbojet engines. We specifically aim on description of control systems using methods and concepts of artificial intelligence, which can bring a new quality in terms of operation and safety of turbojet engines' operation. We also propose a design of intelligent control system for small turbojet engine MPM-20 within the scope of methodology of situational control together with exploration of macro and micro situations concepts.

Keywords: turbojet engine, FADEC, artificial intelligence, control systems

1. INTRODUCTION

The state of present technologies in technical and also non-technical practice implies creation of growing complexity of systems. Turbojet engine as a complex system is multidimensional highly parametric system with complex dynamics and non-linearities. Its particular property is operation in a broad spectrum of changes in environment (e.g., temperatures from -60 to +40 °C). If we want to secure optimal function of such system, it is necessary to develop models and control systems implementing the newest knowledge from the areas of automation, control technology and artificial intelligence (AI). The present control systems and dynamic models are often limited to control or modeling of a complex system in a certain (often operational) state. However, in practice the turbojet engine finds itself in very different working conditions that influence parameters of its operation and characteristics of behavior. By creation of algorithms of control, it is necessary to create models in the whole dynamic spectrum of the modeled system (turbojet engine) and also its erroneous states. Furthermore we need to design a control system that will secure operation converging to optimal one in all eventual states of environment and also inner states of the system represented by its parameters. Except implementation of classic algorithms of control, it is possible to design such systems of control and models by use of progressive methods of artificial intelligence [1]. In the article, we will focus on implementation of methods of situational control as a frame method, which is suitable for use in design of dynamic models and systems of control of turbojet engines with use of intelligent elements.

2. MODERN CONTROL SYSTEMS OF TURBOJET ENGINES

The main global aim of control of turbojet engines is similar to other systems and that is increasing their safety and effectiveness by reduction of costs. This demands

application of new technologies, materials, new conceptions of solutions [6] and also development in systems of control and regulation of aircraft turbojet engines and processes ongoing in them.

Demands for control and regulation systems result mainly from specific properties of the object of control – a turbojet engine. Among the basic functions of control systems of turbojet engine belong the following ones – manual control, regulation of its parameters and their limitation. Manual control and therefore choice of regime of the engine is realized by a throttle lever according to a flight situation or expected maneuver. By regulation of a turbojet engine we understand such a kind of control where the chosen parameters of the engine are maintained on certain set levels, thus keeping its regime.

In the past, the classical control systems of turbojet engines were implemented mainly by hydro-mechanical elements, which however suffered from deficiencies characteristic for such systems. Among such deficiencies were, high mass of such systems, inaccuracies due to mechanical looses and low count of regulated parameters. However development of electronic systems and elements is ongoing, which will allow to increase precision of regulation of parameters of turbojet engines and their count to secure more complex and precise regulation of turbojets.

Use of electronics and digital technologies in control systems of turbojet engines has brought: [6]:

- lowering of mass of control system;
- higher complexity of control – The count of regulated parameters used to be 3 to 7 by hydro-mechanical systems, however the digital systems operate with 12 to 16 parameters;
- increasing of static precision of regulation of different parameters (for example, precision of rotations from $\pm 0.5\%$ to $\pm 0.1\%$, precision of regulation of temperature from $\pm 12\text{K}$ to $\pm 5\text{K}$;
- increase in reliability, service life and economics of operation of the driving unit of an aircraft;
- easier backup, technology of use and repairs, possibility of use of automatic diagnostics.

By design of solution of a control system for a turbojet engine, it is necessary to build an appropriate mathematical model of the engine. The ideal approach to design of electronic systems is a modular one, from hardware or software point of view. This implies use of qualitative processing units that are resistant to noises of environment and also realization of bus systems with low delays is very important in this approach. Further improvement in quality of control can be achieved by implementation of progressive algorithms of control, diagnostics and planning in electronic systems. These algorithms have to be able to assess the state of the controlled system (turbojet engine in our case), then parameterize action elements and they have to be able to control the engine under erroneous conditions represented in outer environment or as errors in subsystems of the engine itself. Prediction of such states represents an area to incorporate predictive control system. Methods of situational control bound with elements of artificial intelligence supply many robust tools for solution of afore mentioned problems and sub-problems.

From the point of view of use of electrical and electronic systems in controls the turbojet control systems can be roughly hierarchically divided into following sets: [2,7]:

1. electronic limiters,
2. Partial Authority Flight Control Augmentation (PAFCA),
3. „High Integration Digital Electronic Control“ (HIDEDEC); „Digital Engine Control“ - (DEC); „Full Authority Digital Engine Control“ - (FADEC)).

The division of control systems into these three levels is not absolutely distinct, as systems on higher level as for example HIDEDEC system can utilize control mechanisms as electronic limiters. For example FADEC systems are often realized as single or double loop control systems with utilization of PI control algorithms or electronic limiters with estimation filters [6,13]. Example of such FADEC algorithm is shown in figure 1 [6].

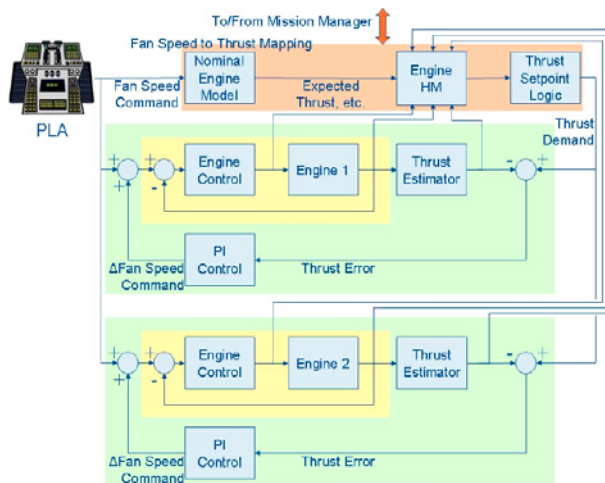

Fig. 1 FADEC control system with implemented PI electronic controllers

Such engine control systems are often integrated into the whole framework of an aircraft control system

together with nominal model predicting optimal thrust of the engine.

3. METHODS OF ARTIFICIAL INTELLIGENCE IN MODELING AND CONTROL OF TURBOJET ENGINES

Methods of artificial intelligence may offer new quality for control systems. However they can bring such benefits only after a careful model based analysis of a system where they should be applied with regards to simplicity and error free operation of such control system. Because on the lowest level of control we deal mostly with data and raw numbers, the approaches of sub-symbolic AI are appropriate to be used in design of intelligent FADEC control systems. However, on higher level of integration some symbolic concepts could also be used. From the area of symbolic AI three basic approaches can be successfully used:

- neural networks
- fuzzy inference systems
- genetic algorithms

All three approaches offer a vast number of methods and their combinations in hybrid architectures. Example of use of a feed-forward neural network with supervised learning as a model used for sensor validation can be seen in figure 2.

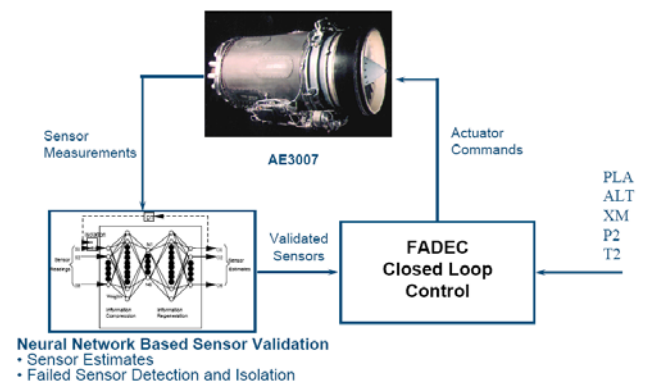

Fig. 2 Neural network based sensor validation with FADEC [14]

Systems of control are today firmly bound with diagnostic systems that work together to solve all situational states that can occur in the engine. Progressive approaches can also be used here, like fuzzy inference systems and neural networks. Our proposal integrates diagnostic module parametrizing all controllers handling different situations in the situational control system (figure 4). Neural network element acts as decision making element and is responsible only for selection of appropriate situational frame, while the diagnostic system can be implemented in a way shown in figure 4. Its implementation and design will be one of the further aims of our work.

Feed-forward topologies can be successfully employed mainly in modeling of non linearities of jet engine and as decision elements in control circuits, for example as a gating neural network in situational control formatter scheme shown in figure 4.

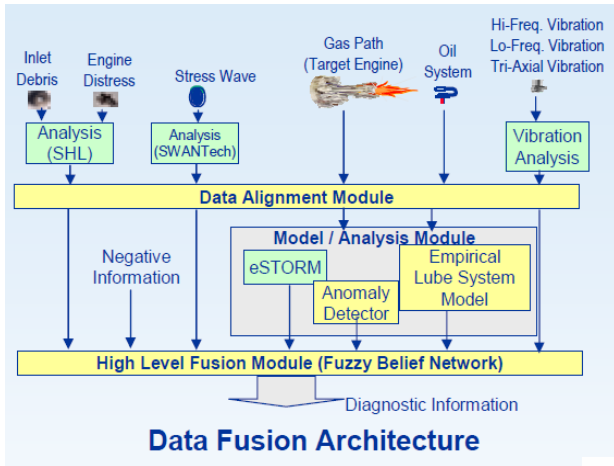

Fig. 3 Data fusion architecture with fuzzy neural network [14]

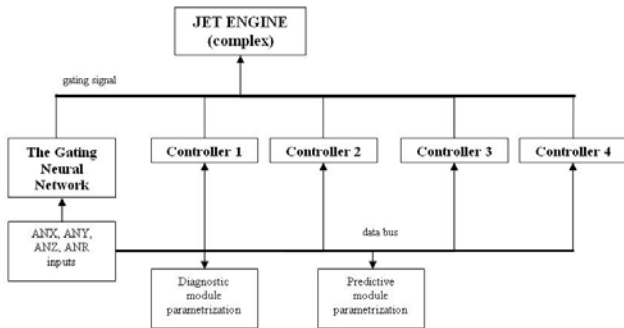

Fig. 4 Neural network acting as a decision element in FADEC compliant jet engine control system [1]

The system shown in figure 4 is development of FADEC (Full Authority Digital Engine Control) compliant control system with situational control methodology approach has been used. Here we use a gating neural network as a classifier of situational frames and system of controllers to handle those situational frames. We use concepts of traditional situational control and formatter control of complex systems [1,2,3]. The system has been described in [8]. The resulting physical architecture including analyzers of input (X), state (Z), output (Y) and desired (R) parameters is shown in the figure 4.

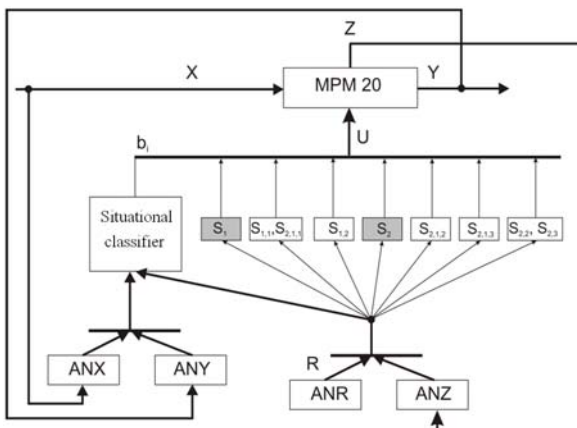

Fig. 5 Situational FADEC control system for MPM 20 engine

4. RESULTS

In design of control algorithms as elements of an integrated control circuit fuzzy inference systems can be successfully used. Such system has been used to design a startup controller for MPM 20 - the experimental small turbojet engine. This controller is acting only by startup of the engine and its aim is to decrease the temperature overshoot by startup that decreases life cycle of the engine and in certain cases can lead to turbine engine damage. The present startup techniques are mainly time based, what means that the fuel flow input is increased in a time based function rather than parameter based. The control algorithm can be seen as controller 1 in the figure 4 and is bound with digitally controlled servo vent for fuel supply control.

The basic idea is to decompose the startup process of the engine into model micro-situational frames, where one rule of the inference system would correspond to one micro-situational frame in the start-up macro-situational frame. Each rule in the form of <if> ... <then> ... postulate has a corresponding output value of fuel supply assigned. In this way we can handle not only the classical situations at startup, but also emergency situations like stall of the engine or fire in the engine at startup. Three inputs and one output were chosen for the rules so the rule looks like this:

$$\text{IF } T4c \text{ IS } L\{T4c\} \text{ AND } dT4c \text{ IS } L\{dT4c\} \text{ AND } n \text{ IS } L\{n\} \text{ THEN } Qpal \text{ IS } L\{Qpal\} \quad (1)$$

where

- $T4c$ – temperature of gases behind the turbine
- $dT4c$ – derivation of temperature of gases behind the turbine
- n – speed of the engine
- $Qpal$ – fuel flow supply to the engine
- L – function that assigns fuzzy membership function in corresponding universe of the afore mentioned parameters.

In this way the fuzzy controller handles 60 micro-situations with a small excerpt shown in the following table.

Table 1 Definition of micro-situations of the startup controller

28	if	n	is	PS	and	T ₄	is	PB	and	dT ₄	is	Z	THEN	Q _{pal}	is	PM	
29	if	n	is	PS	and	T ₄	is	PB	and	dT ₄	is	PS	THEN	Q _{pal}	is	PS	
30	if	n	is	PS	and	T ₄	is	PB	and	dT ₄	is	PM	THEN	Q _{pal}	is	PS	Critical dT4
31	if	n	is	PM	and	T ₄	is	PS	and	dT ₄	is	NM	THEN	Q _{pal}	is	Z	Stall
32	if	n	is	PM	and	T ₄	is	PS	and	dT ₄	is	NS	THEN	Q _{pal}	is	Z	Stall
33	if	n	is	PM	and	T ₄	is	PS	and	dT ₄	is	Z	THEN	Q _{pal}	is	Z	Stall
34	if	n	is	PM	and	T ₄	is	PS	and	dT ₄	is	PS	THEN	Q _{pal}	is	PB	
35	if	n	is	PM	and	T ₄	is	PS	and	dT ₄	is	PM	THEN	Q _{pal}	is	PS	
36	if	n	is	PM	and	T ₄	is	PM	and	dT ₄	is	NM	THEN	Q _{pal}	is	PB	
37	if	n	is	PM	and	T ₄	is	PM	and	dT ₄	is	NS	THEN	Q _{pal}	is	PB	
38	if	n	is	PM	and	T ₄	is	PM	and	dT ₄	is	Z	THEN	Q _{pal}	is	PB	Final Rule
39	if	n	is	PM	and	T ₄	is	PM	and	dT ₄	is	PS	THEN	Q _{pal}	is	PM	
40	if	n	is	PM	and	T ₄	is	PM	and	dT ₄	is	PM	THEN	Q _{pal}	is	PS	
41	if	n	is	PM	and	T ₄	is	PB	and	dT ₄	is	NM	THEN	Q _{pal}	is	PM	
42	if	n	is	PM	and	T ₄	is	PB	and	dT ₄	is	NS	THEN	Q _{pal}	is	PM	
43	if	n	is	PM	and	T ₄	is	PB	and	dT ₄	is	Z	THEN	Q _{pal}	is	PS	Critical dT4
44	if	n	is	PM	and	T ₄	is	PB	and	dT ₄	is	PS	THEN	Q _{pal}	is	Z	
45	if	n	is	PM	and	T ₄	is	PB	and	dT ₄	is	PM	THEN	Q _{pal}	is	Z	Fire

Where rules in yellow color represent critical temperature states, blue color represent stall of the engine, red color represents rule handling fire of the engine and green color represents the final rule after execution of which control is handled to another controller and engine transits from startup macro-situation into another macro situational frame. The last figure shows the control surface of the startup macro-situation for MPM-20 engine in case of $dT4c$ is zero.

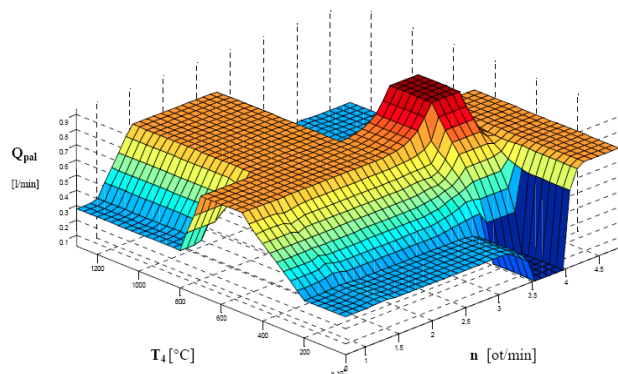

Fig. 6 Control surface of the startup controller

5. CONCLUSIONS

The object of a small turbojet engine MPM 20 gives us an ideal test bed for research of methods in the areas of non-linear dynamic systems modeling and design of advanced control algorithms. Further research will be done in the area of situational modeling that will be headed towards broadening of input parameters of the situational model of the engine and further refinement of situational classes designation. In this area we will be aimed at use of automatic algorithms to find boundaries between situational frames within multivariate space of parameters contrary to their setting by an expert. Anytime control algorithms represent other area of our interest with great possibilities of application of intelligent algorithms that will deal with critical states of operation of the engine and will be further embedded in the whole system of situational control of the engine. Design of such algorithms demands also further refinement of proposed models. All research in the areas of situational modeling, situational control and anytime algorithms should bring new quality of control and modeling in the area of turbojet engines and we expect this knowledge to be also expanded to other areas of technical systems.

ACKNOWLEDGMENTS

The work was supported by project: VEGA no. 1/0394/08 – Algorithms of situational control and modeling of large scale systems.

REFERENCES

- [1] Andoga, R., Madarász, L., Föző, L.: Situational modeling and control of a small turbojet engine MPM 20, IEEE International Conference on Computational Cybernetics, 20.-22. August, 2006, Tallinn, Estonia, pp. 81-85, ISBN 1-4244-0071-6.
- [2] Andoga, R.: Hybrid methods of situational control of complex systems, Dissertation Thesis, Technical University of Košice, 2006, pp.120.
- [3] Beneš, J.: *Teorie systémů (řízení komplexů)*, (Theory of systems (control of complexes)), 200 pp. Academia, Nakladatelství ČSAV, 1974.
- [4] Harris, Ch., Hong, X., Gan, Q.: Adaptive Modelling, Estimation and Fusion from Data, Springer, ISBN 3-540-42686-8, pp. 323, 2006.
- [5] Hocko, M.: *Hodnotenie stavu LTKM na základe zmeny termodynamických parametrov*, (Evaluation of state of LTKM based on changes of thermodynamic parameters), Dissertation Theses, The Air Force Academy of General M. R. Štefanik, Košice, 2003.
- [6] Litt, J. S., Turso, J. A., Shah, N., Sowers, T. S., Owen, K. A.: A Demonstration of a Retrofit Architecture for Intelligent Control and Diagnostics of a Turbofan Engine, NASA/TM-2005-214019, 2005.
- [7] Lazar, T. et al.: *Tendencie vývoja a modelovania avionických systémov*, (Tendencies of development and modeling of avionic systems), Ministry of Defence of the Slovak Republic, pp. 160, 2000, ISBN 80-8842-26-3.
- [8] Andoga, R., Madarász, L., Föző, L.: Digital electronic control of a small turbojet engine MPM 20. In: Acta Polytechnica Hungarica. vol. 4, no. 4 (2007), p. 83-95. ISSN 1785-8860.
- [9] Madarász, L.: *Inteligentné technológie a ich aplikácie v zložitých systémoch*, (Intelligent technologies and their applications in complex systems), Elfa, s.r.o., Košice, 2004, 349 pp., ISBN 80-89066-75-5
- [10] Moller, M. F.: A scaled conjugate gradient algorithm for fast supervised learning, Neural Networks, vol. 6, 1993, pp. 525-533.
- [11] Pospelov, D. A.: *Situacionnoje upravlenije. Teoria i praks. Nauka*, (Situational control, theory and practice), Moskva, 1986, 284 pp.
- [12] Ružek, J., Kmoch, P.: *Teorie leteckých motoru I.* (Theory of aircraft engines I.), 373 pp., 1979.
- [13] Sanjay, G.: Fundamentals of Aircraft Engine Control Design Course, Lecture, September 15, 2007, NASA Glenn Research Center, 2007.
- [14] Sanjay, G.: NASA Glenn Research in Controls and Diagnostics for Intelligent Propulsion Systems, NASA/TM 2005-214036, 2005.
- [15] Wiseman, M.: Intelligent Engine Systems, NASA CR/-2005-213964, 2005.
- [16] Zilberstein, S.: Using Anytime Algorithms in Intelligent Systems. AI Magazine, vol. 17, no. 3, pp. 73-83, 1996.

Received December 3, 2009, accepted January 29, 2010

BIOGRAPHIES

Rudolf Andoga was born on 22.08.1980. In 2003 he graduated (MSc) at the department of Cybernetics and Artificial Intelligence of the Faculty of Electrical Engineering and Informatics at Technical University in Košice. He defended his PhD in the field of control and automation systems; his thesis title was "Hybrid algorithms of situational control of complex systems". Since 2006 he is working partly as a tutor with the Department of Cybernetics and Artificial Intelligence and mainly at the Department of Avionics. His scientific research is focusing on application and methodology of intelligent control systems in avionic systems and with control of complex systems.

Ladislav Főző was born on 21.7.1982. In 2005 he graduated (MSc) at the department of Cybernetics and Artificial Intelligence of the Faculty of Electrical Engineering and Informatics at Technical University in Košice. He defended his PhD in the field of control and automation systems; his thesis title was "Anytime control algorithms of complex systems". Since 2006 he is working partly as a tutor with the Department of

Cybernetics and Artificial Intelligence and partly at the Department of Environmental Studies and Information Engineering. His scientific research is focusing on anytime algorithms, analytic modelling of complex systems and control algorithms of turbojet engines.

Ladislav Madarász was born on 16.6.1949. In 1973 he graduated (MSc) at the department of Cybernetics at Košice Technical College. He obtained his professor degree in 1994 in the field of control and automation systems. He is working as a professor at the Department of Cybernetics and Artificial Intelligence. His scientific research is focusing situational control of complex systems, complex automation, and in general in application of elements means and approaches of artificial intelligence in modeling, projecting and diagnostics and control of complex systems.

Tomáš Karol' was born on 26.10.1984. In 2009 he graduated (MSc) at the department of Cybernetics and Artificial Intelligence of the Faculty of Electrical Engineering and Informatics at Technical University in Košice. Since 2009 he is a PhD. student at the Department of Cybernetics and Artificial Intelligence. His scientific research is focusing on embedded supervision of complex systems.